

F9J GCBG

97 F	F9J GCB	89G7 F-DHC B	7<5B: 98 6M	85H9	5DDFCJ 98 6M
' &- &	:	7 C B J 9FH98 A 5H9F 5@HC '%'; 5"	>7	%'\$#%/#&\$%*	: <

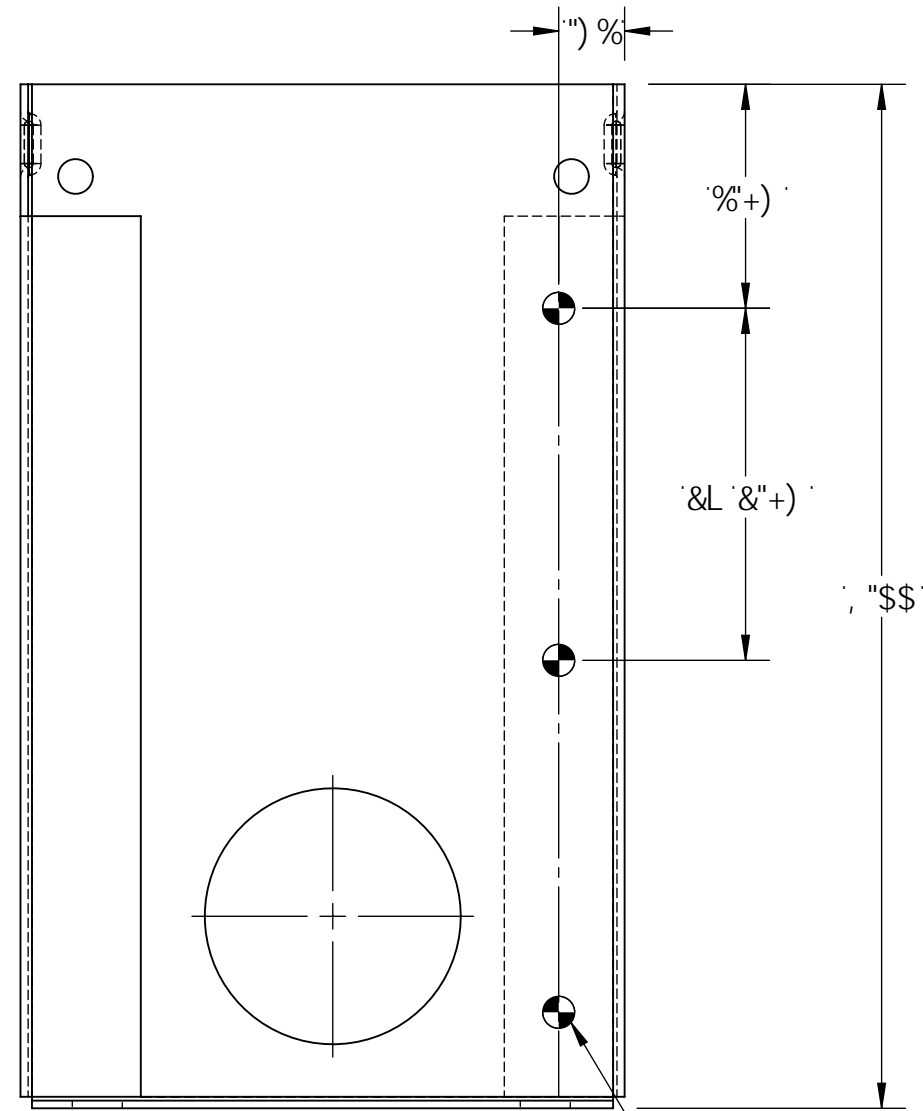

DF-€ F 'HC' DCK 89F 7 C 5 H
 ' L 'GDC HK 9@8 ' ['&' -!, 15] 'HC' ['&' -!, 16]
 9J 9B @MGD5 7 98 C B '&': @5B; 9G5GG<C K B

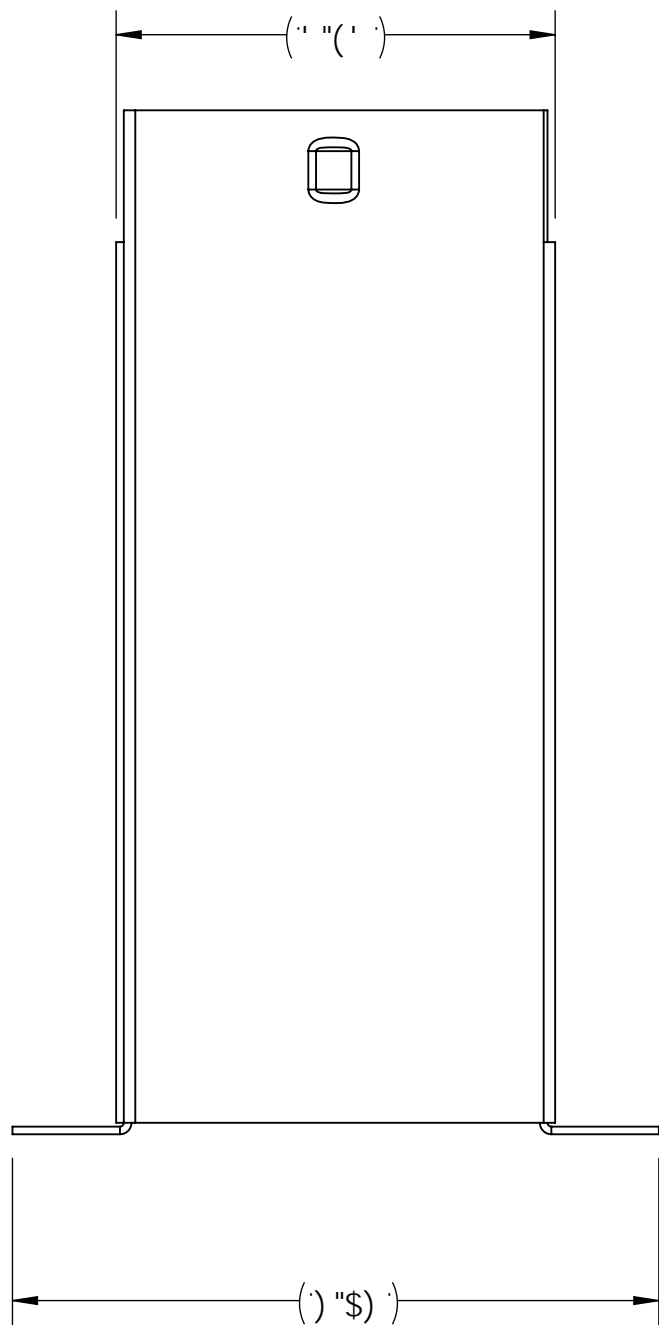
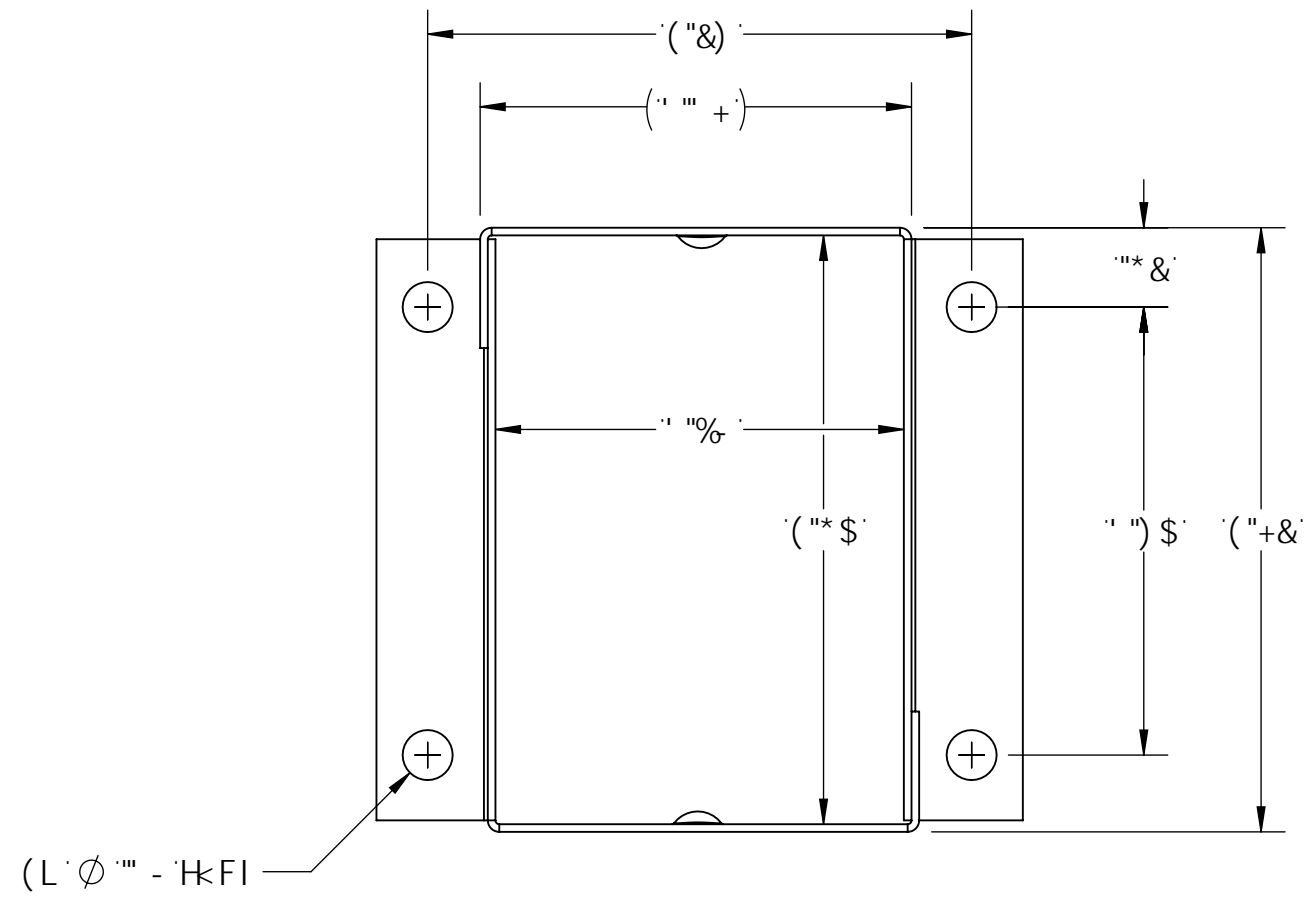
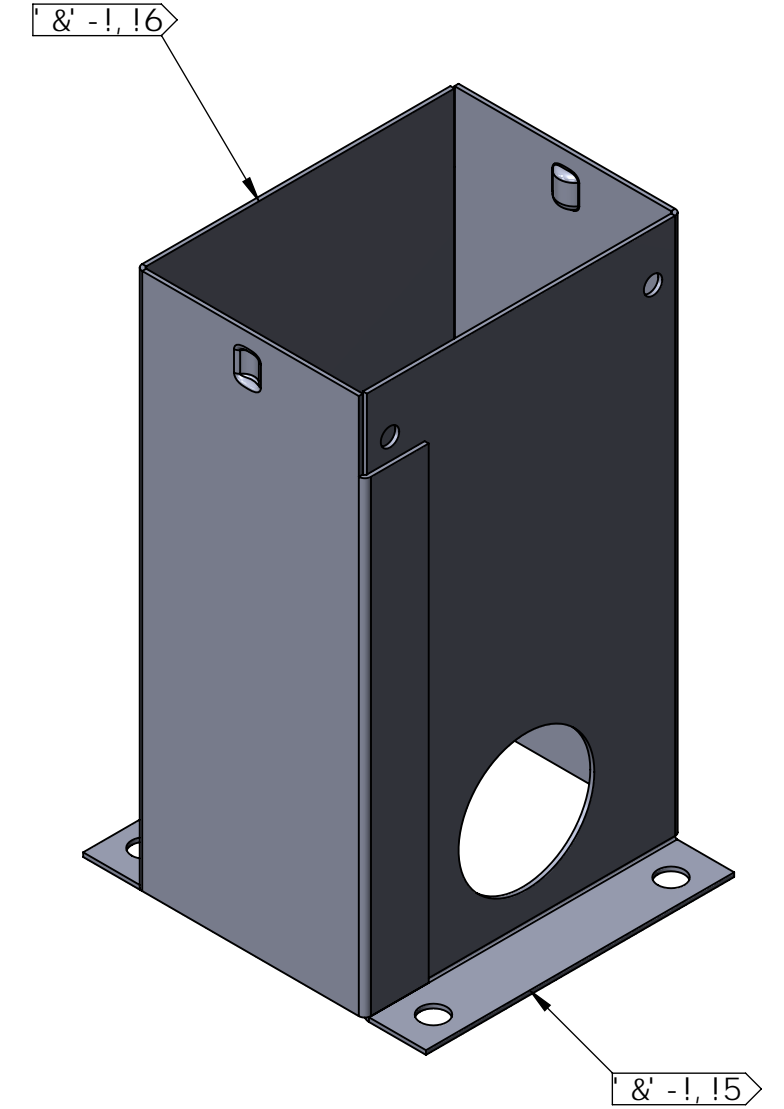

#9A 'BC "	D5FHBI A 69F	89G7 F-DHC B	E HM
%	' & -!, 15	7 C BGC @'65 G9', "	%
&	' & -!, 16	7 C BGC @'65 G9', "	%
<p>5 DG7 C ,%, '95 GH'((H<'GHF99H HI @5ZC?'+(%) ft % L' &!) *\$\$</p>		<p>HH99: 7 C BGC @'65 G9', "'5J 'G9F 9G</p>	
<p>HM9C: DFC>97 HCB A 5HF 5@ 7 FG%: 5" (f's) - , 'H?'L'5' %\$\$, 'FA '\$\$%\$\$)</p>		<p>8K ; "'BC" ' & -!,</p>	
8F5K B	>7	85H9	%'\$#%/#&\$%*
7<97798	85H9	85H9	%'\$#%/#&\$%*
8>	%'\$#%/#&\$%*	%'\$#%/#&\$%*	%'\$#%/#&\$%*
5DDFCJ 98	85H9	%'\$#%/#&\$%*	%'\$#%/#&\$%*
: 85@	85H9	%'\$#%/#&\$%*	%'\$#%/#&\$%*
: <	85H9	%'\$#%/#&\$%*	%'\$#%/#&\$%*
<p>DC K 89F 7 C 5 H@: <H G9A #: @CGHHLH F98' 6@57?</p>		<p>G<99HG+99 G7 5 @ F9J GCB 8C BCG7 5@8F5K B: 5D9B\$\$\$</p>	
<p>#B. ' & -!,</p>		<p>G<H' %C :)</p>	