

REVISIONS					
ECR	REVISION	DESCRIPTION	CHANGED BY	DATE	APPROVED BY
3709	A	NEW RELEASE	RR	3/25/2019	RT

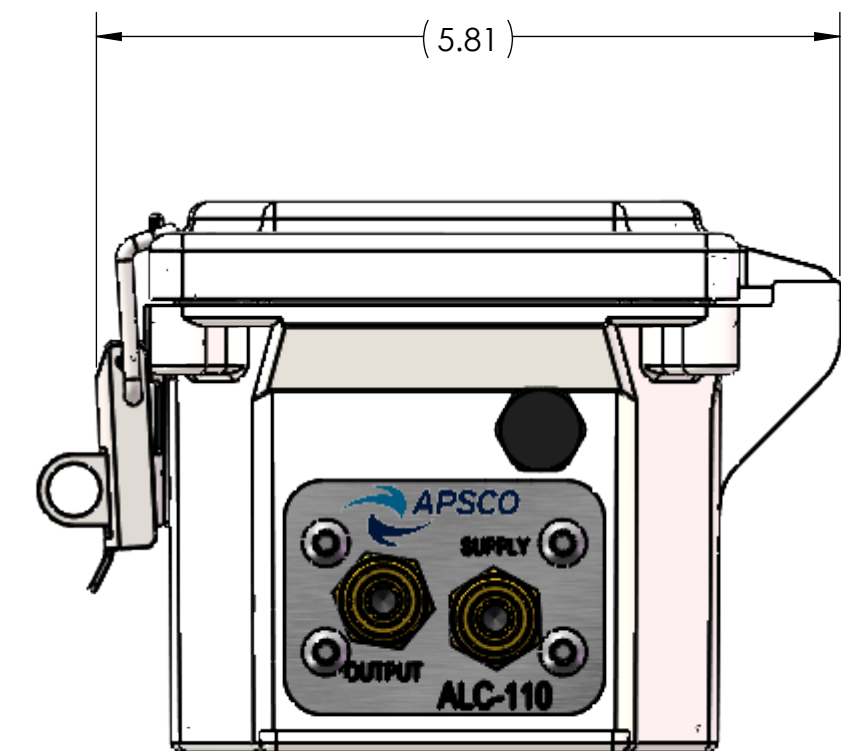

PROPRIETARY AND CONFIDENTIAL
 THE INFORMATION CONTAINED IN THIS DRAWING IS THE SOLE PROPERTY OF APSCO Inc.. ANY REPRODUCTION IN PART OR AS A WHOLE WITHOUT WRITTEN PERMISSION OF APSCO Inc. IS PROHIBITED.

TYPE OF PROJECTION		MATERIAL
 THIRD ANGLE PROJECTION		N/A
DRAWN	DATE	FINISH
RR	3/25/2019	
CHECKED	DATE	
VD	3/25/2019	
APPROVED	DATE	N/A
RT	3/25/2019	
FINAL	DATE	
KT	3/25/2019	

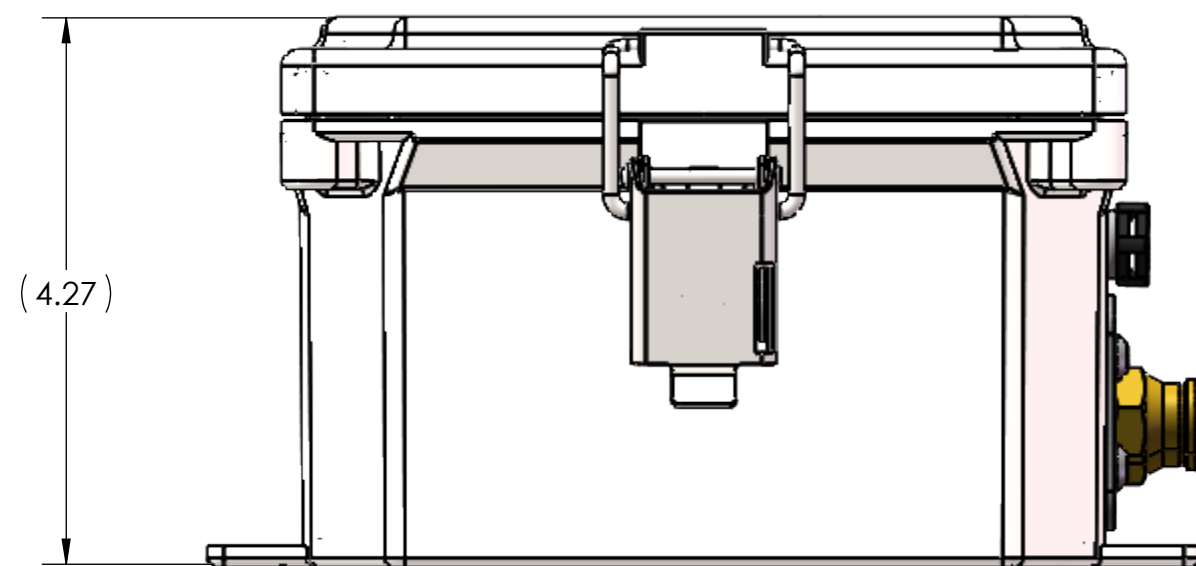
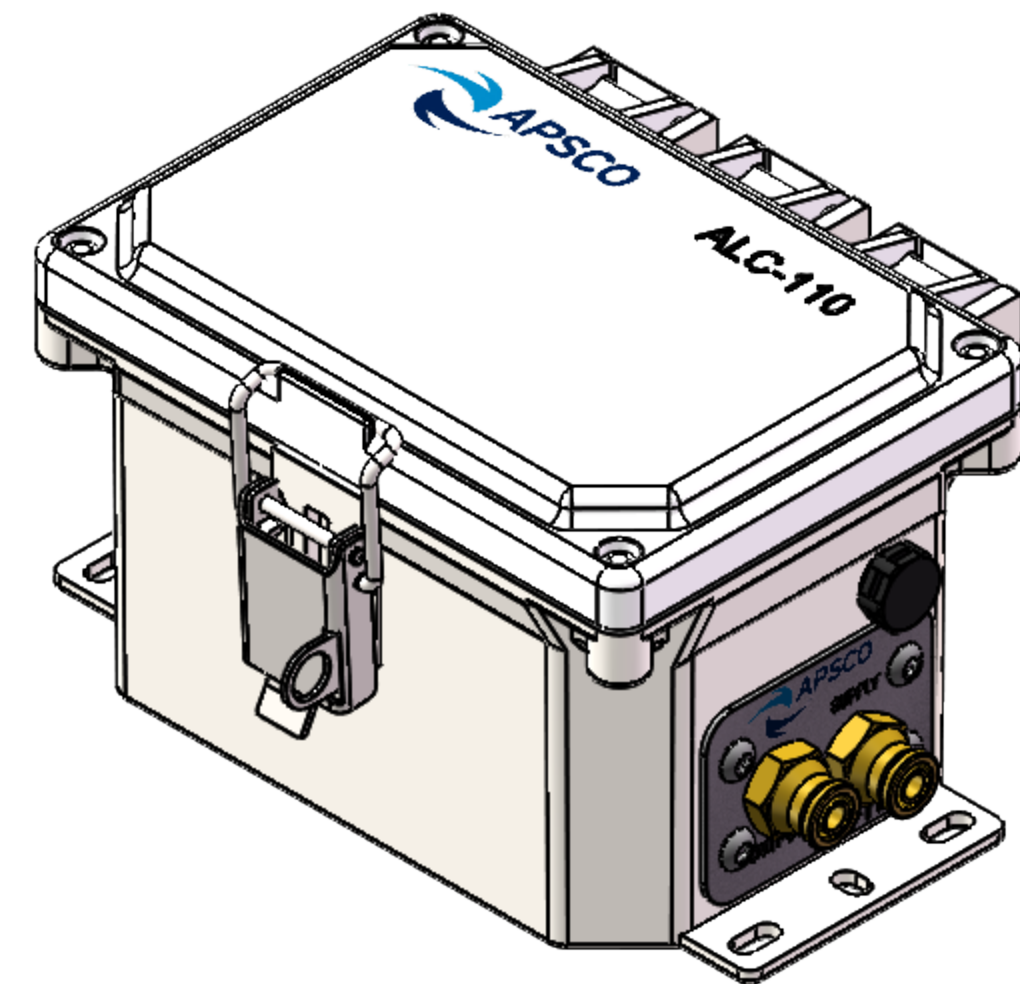
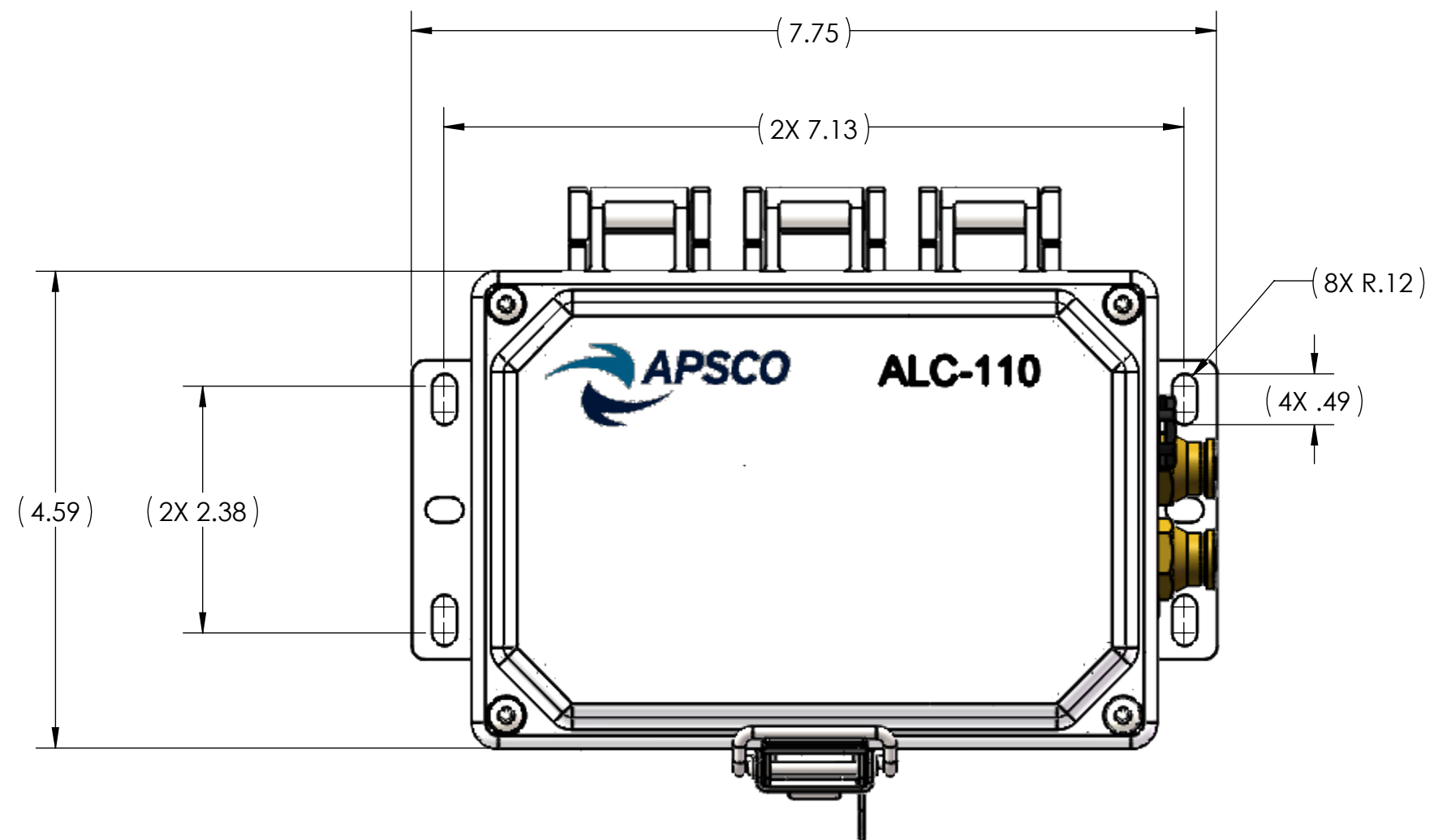
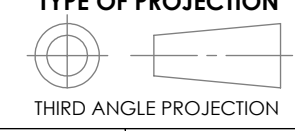

TITLE: LIFT AXLE CONTROL 110		
UNLESS OTHERWISE SPECIFIED DIMENSIONS ARE IN INCHES TOLERANCES ARE:		DWG. NO. ALC-110
DECIMALS .X = ±.06 .XX = ±.03 .XXX = ±.010	SURFACE FINISH: 63 ANGLES ± 2° HOLES ± .005 HOLES LOCATION ± .005	SHEET SIZE C
DO NOT SCALE DRAWING		SCALE 2:3
F/N: ALC-110		REVISION A
		SHT. 1 OF 2