

FOR COMMERCIAL G-101 & G-102 PUMP VALVE
INSTALLATION INSTRUCTIONS FOR C-3508-DM

1. Make sure that the shaft and valve face are free from any foreign particles.
2. Remove poppet and spring from cover.
3. Remove the two screws that hold poppet cover in place. Discard cover, screws, remove snap rings and seal retainer plate.
4. Prepare cylinder for installation
 - a. Remove seal ring from cylinder body
 - b. Remove piston assembly from cylinder body
 - c. Remove setscrew from piston assembly using a 5/32 hex wrench
5. Grease and slide seal ring over hydraulic valve spool placing face o-ring against valve face.
6. Slide piston assembly over valve spool with spring assembly closest to valve body. Apply Loctite to threads of set screw and install in piston through the hole in the valve spool.
7. Lubricate piston o-ring then slide cylinder body assembly in place, secure to valve using 3/16 hex wrench on capscrews. Torque capscrews 6 to 9 ft-lbs.
8. Install air lines and test for proper operation.

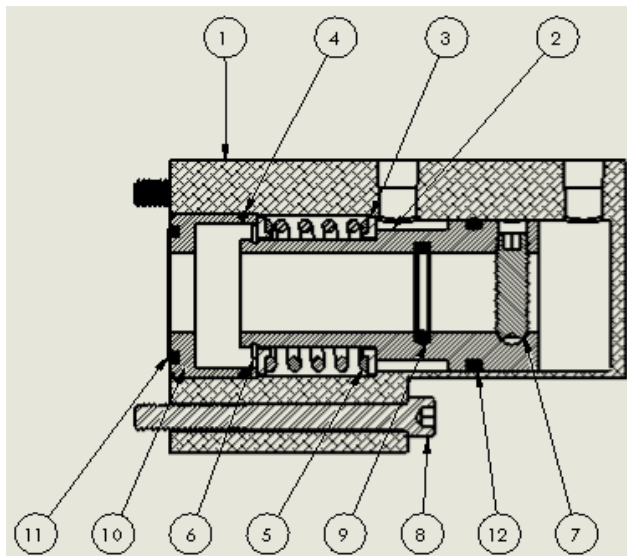

ITEM NO.	PART NUMBER	DESCRIPTION	QTY.
1	4103	CYLINDER BODY C-3508-DM	1
2	4104	PISTON 1-3/8 X 2.75 LG C-3508-DM	1
3	4105	SPACER 1 1/2 ALUM RD	2
4	4106	SEAL RING 1 1/2 RD ALUM	1
5	4107	SPG 1.15 ID 1.38 OD 1.5 LG	1
6	2804	SNAP RING EXT 1.0	1
7	3312	SCREW SET 5/16-18 X 1 CUP PT	1
8	3406	CAPS 1/4-20 X 2 1/2 SH	2
9	1759	O-RING 2-116 15/16 OD 3/4 ID	1
10	2074	O-RING 2-028 1 1/2 OD 1 3/8 ID	1
11	3691	O-RING 2-121 1-1/4 OD 11/16 ID	1
12	4108	O-RING 2-123 1 3/8 OD 1 3/16 ID	1